

- 12 kHz to > 40 GHz
- 7 ps Risetime

The Model 5542LL is an ultra-broadband, coaxial dual bias insertion tee and DC blocking capacitor. It passes ultra-fast rise pulses with a minimum of waveform distortion. Its risetime is only 7 ps. The frequency response is flat over many decades, and the -3 dB bandwidth extends from 12 kHz to beyond 40 GHz. It is now available with your choice of either 2.92 mm, 40 GHz, or 2.4 mm, 50 GHz connectors. The 2.92 mm connector is mechanically and electrically compatible with SMA and 3.5 mm connectors. The 2.4 mm connector is mechanically and electrically compatible with the 1.85 mm connector. This bias tee is ideal for 40 Gbit systems and other RF and microwave applications. It has two DC inputs to apply independent DC bias to each RF port. In addition, it is packaged in an extremely compact housing.

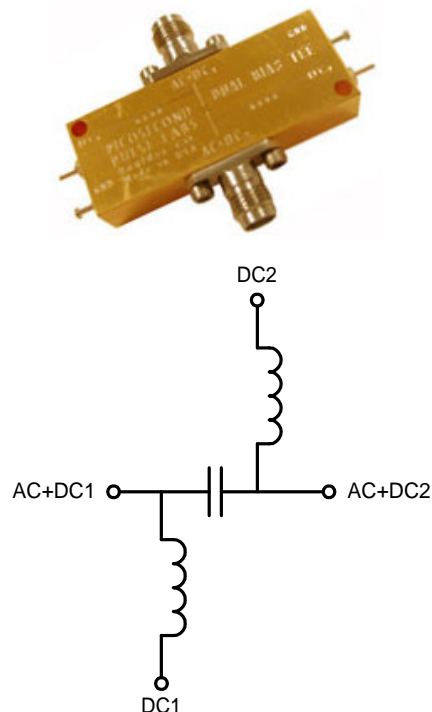

5542LL Electrical Specifications

Risetime (10%-90%)	7 ps typical	Capacitance	0.22 μ F, -50% +80%
Bandwidth (-3 dB)	>40 GHz guaranteed	DC Voltage	16 V max.
Low Frequency (-3 dB)	12 kHz typical	Inductance each DC path	1.5 mH, \pm 20%
Insertion Loss See guaranteed limit lines, S_{21} plot	0.2 dB mid-band	DC Current each DC path	100 mA max.
		Resistance each DC path	5.6 Ω
Impedance	50 Ω	RF Power	5 W avg. max., $f < 10$ GHz
Return Loss	>20 dB, 1 MHz to 4 GHz >13 dB, $f < 20$ GHz	DC Path Bandwidth	8 kHz typical
		Delay	140 ps
Isolation	>50 dB, $f > 100$ MHz	Dimensions	See drawing, p. 3
		Warranty	One year

Ordering Information

Model Number	Connector Configuration *
5542LL-204	2.4 mm jacks (f) on AC+DC ₁ & AC+DC ₂ , solder pins on DC ₁ & DC ₂
5542LL-221	2.92 mm jacks (f) on AC+DC ₁ & AC+DC ₂ , solder pins on DC ₁ & DC ₂
5542LL-223	2.92 mm jack (f) on AC+DC ₁ , 2.92 mm plug (m) on AC+DC ₂ , solder pins on DC ₁ & DC ₂
5542LL-227	2.92 mm plug (m) on AC+DC ₁ , 2.92 mm jack (f) on AC+DC ₂ , solder pins on DC ₁ & DC ₂
5542LL-234	2.92 mm plugs (m) on AC+DC ₁ & AC+DC ₂ , solder pins on DC ₁ & DC ₂

* Other connector combinations may be available on request.

Microwave Frequency Response

Linear sweep from 0.04 to 40 GHz (4GHz/div).

AC+DC₁ connector is input (port 1). AC+DC₂ connector is output (port 2)

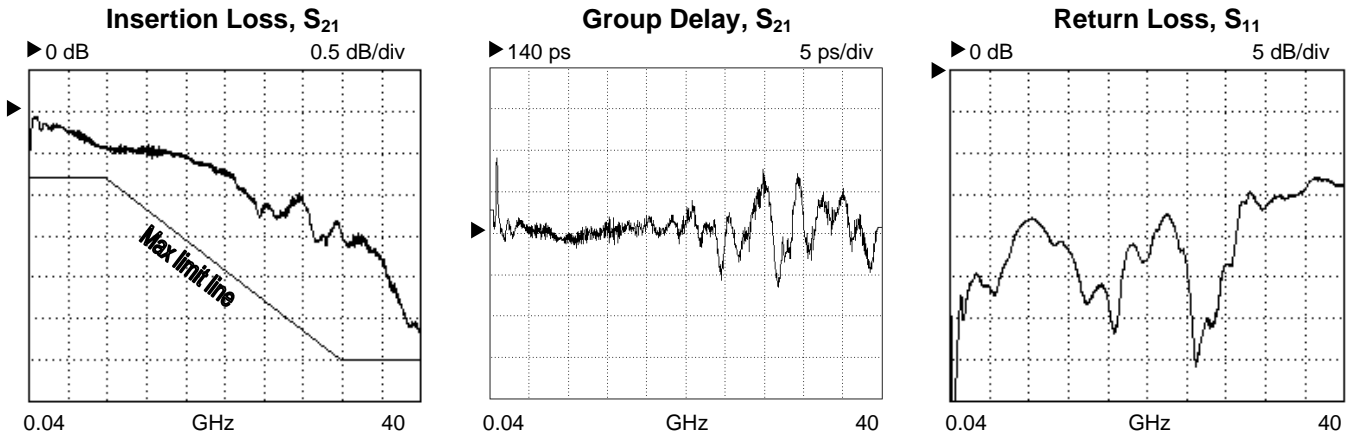

Typical Frequency Domain Response

Log sweep from 10 kHz to 50 GHz. Insertion loss scale is 0.5 dB/div. Return loss scale is 5 dB/div.

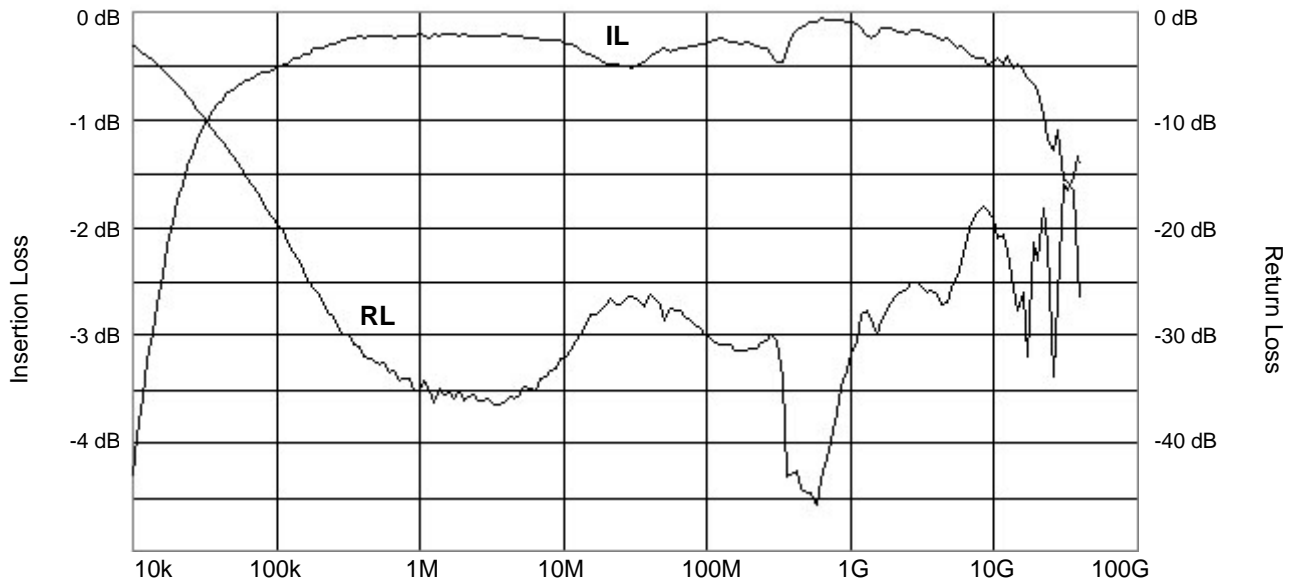

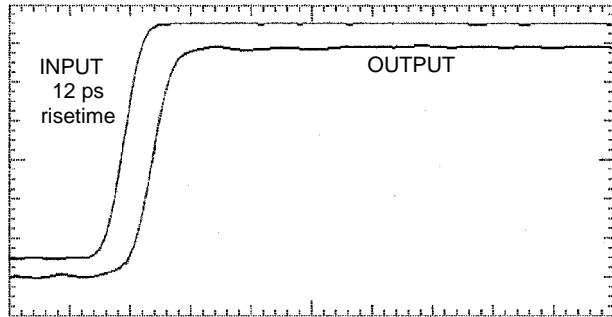

Step Response, 20 ps/div

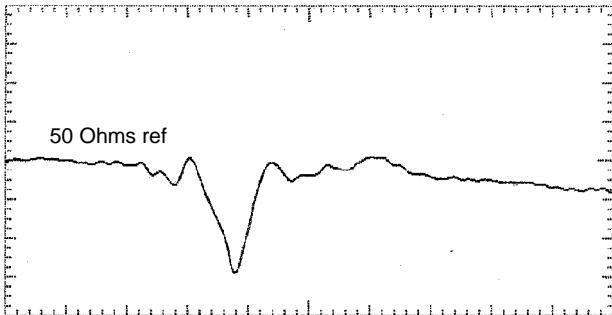

2% rho/div, 100 ps/div
25 ps TDR of AC input port

5542LL Mechanical Drawing

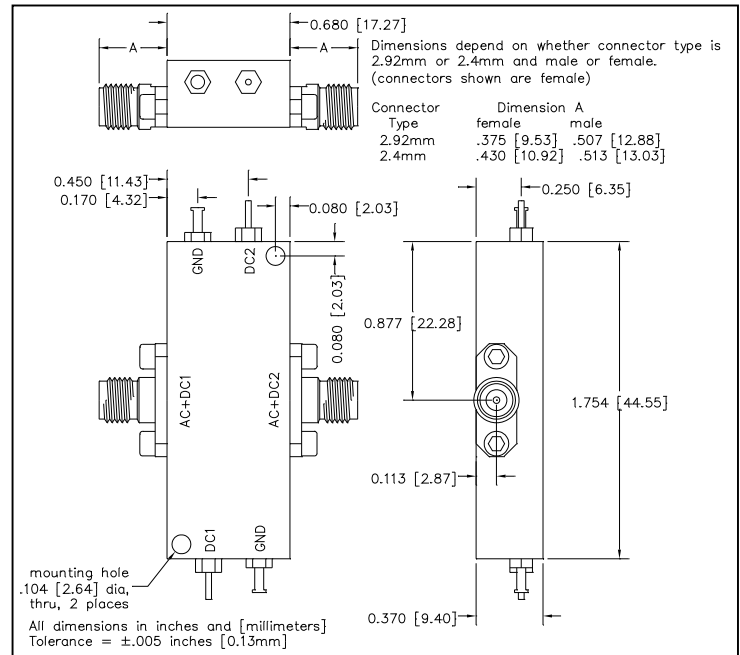

Notes

- [1] Parameters listed in table and shown on plots are typical values. The -3 dB bandwidth and the insertion loss frequency response are guaranteed to be within the limits shown.
- [2] Frequency response measured using an HP-3577A, 5 Hz -200 MHz and a Wiltron 37369A, 40 MHz - 40 GHz vector network analyzers.
- [3] Step response measured using a PSPL Model 4015C pulse generator and an HP-54124A, 50 GHz oscilloscope. See AN-5a for details.